

Jan. 4, 1966

A. H. BAHNSON, JR

3,227,901

ELECTRICAL THRUST PRODUCING DEVICE

Filed Sept. 15, 1961

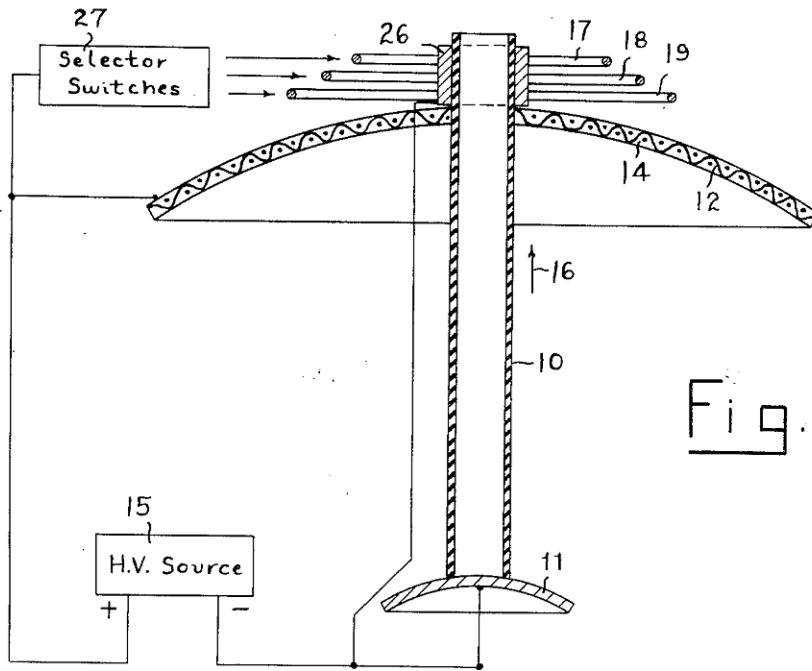

Fig. 1

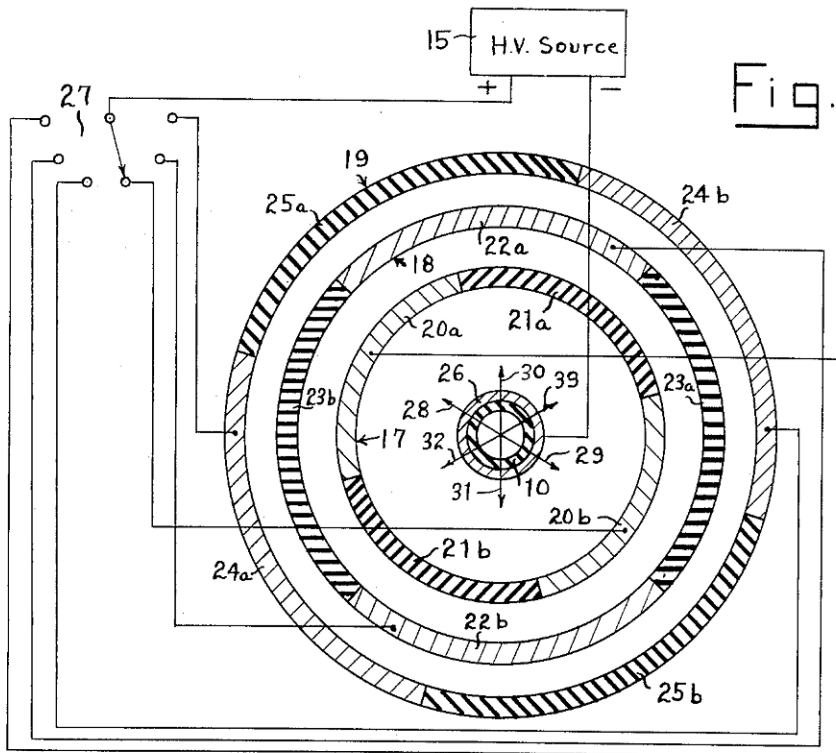

Fig. 2

3,227,901

ELECTRICAL THRUST PRODUCING DEVICE

Agnew H. Bahnsen, Jr., 1001 S. Marshall St.,
Winston-Salem, N.C.

Filed Sept. 15, 1961, Ser. No. 138,493

5 Claims. (Cl. 310-5)

This invention relates to a device for directly producing thrust in response to the application of electrical energy and is a continuation-in-part of my co-pending applications Serial No. 745,652 filed June 30, 1958, now abandoned and Serial No. 34,522 filed June 7, 1960, now abandoned.

In my aforesaid parent application, there is disclosed and claimed an improved arrangement for producing thrust wherein the thrust producing device is comprised of a pair of main electrodes supported in spaced relationship with each other by means of a dielectric member and a difference in potential is applied to the electrodes to effect a thrust on the device in the direction of the longitudinal axis of the assembly of support and electrode members.

The present invention is directed to a further organization of elements by which one is enabled to obtain a thrust laterally of said longitudinal axis in any one of a plurality of selected lateral directions. In accordance with one embodiment of the invention which will be hereinafter described in detail, an auxiliary cylindrical electrode is secured to the periphery of the dielectric supporting member for the main electrodes and a plurality of other auxiliary electrodes are spaced in different radial positions with respect to the auxiliary cylindrical electrode. These electrodes are selectively energized to produce a lateral thrust in a desired direction. Advantageously, the auxiliary electrodes having different radial positions may be constituted by conductive arcuate portions of a plurality of rings, the conductive portions of each ring being separated by arcuate portions of dielectric material, and the rings being arranged concentrically with respect to the auxiliary cylindrical electrode and encircling the support and also being carried by the support.

More specifically, the embodiment of the invention which will be described is comprised of three rings, each such ring being provided with a pair of oppositely disposed arcuate conductive portions and the respective pairs of conductive portions of each ring having their centers mutually displaced by 60°. Each electrode is selectively energized from a source of direct current potential relative to the inner cylindrical electrode so as to develop a lateral thrust in any selected one of six different directions having their directional thrust axes spaced 60° apart. Such an embodiment is illustrated in the accompanying drawings, in which:

FIG. 1 is a view in vertical central section of the thrust producing device; and

FIG. 2 is a view showing the detailed arrangement of the three auxiliary lateral thrust producing electrode rings together with the circuit means for their selective energization.

With reference now to FIG. 1, a thrust producing device is depicted which comprises a dielectric member 10 which is in the form of a hollow cylinder and may advantageously comprise a high dielectric material. Mounted on the lower end of the dielectric member 10 is an arcuate electrode 11 made of electrically conductive material. Mounted further along the body of the dielectric member 10 is an arcuate electrode member 12 which surrounds the member 10. The arcuate electrode 12 which has an expanded surface relative to that of electrode 11 may be comprised of a series of fine electrically

conductive wires 13 embedded in a suitable dielectric material 14.

A source of high direct current voltage indicated schematically at 15 and which can be supported generally within the dielectric member 10, if desired, has its positive (+) terminal connected to the arcuate electrode member 12 and its negative (-) terminal connected to electrode 11. The resulting forces which develop as a result of the application of this high direct current potential to electrodes 11 and 12 cause a thrust to be developed on the dielectric member 10 longitudinally thereof in the direction of the arrow 16.

In accordance with the present invention, thrust on the member 10 may also be developed in a selected lateral direction, i.e. in a direction normal to the longitudinal axis of the dielectric member 10. This lateral thrust is brought about by arranging auxiliary electrodes laterally of the dielectric member 10 and in different radial positions. In one practical embodiment of the invention, as shown in detail in FIG. 2, the auxiliary electrodes are arranged in the form of rings which surround and are concentric with the dielectric member 10 and are carried by the latter by means of suitable supporting structure not shown. There are three of these rings denoted by the numerals 17, 18 and 19. Each ring is composed of two 90° arcuate portions of electrically conductive material and two 90° arcuate portions of dielectric material, and the dielectric portions alternating with the electrically conductive portions so that the portions of electrically conductive material are thereby oppositely disposed with respect to the center of the ring. The conductive portions of ring 17 are denoted by 20a and 20b and the dielectric portions by 21a and 21b. The conductive portions of ring 18 are denoted by 22a and 22b and the dielectric portions by 23a and 23b. The conductive portions of ring 19 are denoted by 24a and 24b and the dielectric portions by 25a and 25b.

Located within these rings 17-19 is an auxiliary cylindrical electrode 26 which is concentric with the axis of the dielectric supporting member 10 and which is conveniently mounted on the periphery of the latter.

In order to develop six different directions of lateral thrust upon the dielectric member 10 from the three rings 17-19 depicted in FIG. 2, and the cylindrical electrode 26 it will be noted that the center of the conductive portion 20a, 20b of inner ring 17 is displaced by an angle of 60° from the center of the conductive portions 22a, 22b, of the intermediate ring 18, and that the center of the conductive portions 24a, 24b of the outer ring 19 is displaced by an angle of 60° from the center of the conductive portion 22a, 22b of intermediate ring 18. To develop the thrust in a direction laterally of the longitudinal axis of the dielectric member 10, arrangements are made to apply an electrical potential in an alterantive and selective manner between electrode 26 and any one of the conductive portions 20a, 20b, 22a, 22b, 24a and 24b. The potential source 15 used for energizing the main electrodes 11 and 12 which produce the thrust longitudinally of the dielectric member 10 can be used for this purpose. The circuit for energizing the electrodes can include conventional rotary switch means 27. Thus one arcuate electrode is always charged positively with respect to the negatively charged cylindrical electrode 26 and the direction of the lateral thrust from the center will be towards the particular electrode connected to the positive terminal of the direct current voltage source 15.

Thus, for example, if a lateral thrust in the direction of the arrow 28 in FIG. 2 is desired, electrode 20a will be energized, in which event, electrode 20a will be connected through switch 27 to the positive terminal of the

3

direct current voltage source 15. If it is desired to reverse the direction of thrust by 180°, so that the direction is along arrow 29, then the arm on selector switch 27 will be shifted whereupon electrode 20b will be connected to the positive terminal.

In a similar manner, the direction of the lateral thrust along arrow 30, or reversed along arrow 31, can be obtained by energizing electrodes 22a or 22b, and the direction of lateral thrust along arrow 32, or reversed along arrow 33, can be obtained by energizing electrodes 24a or 24b.

In conclusion, it is to be understood that while the foregoing embodiment constitutes one practical construction for the thrust producing device, various modifications of the construction and arrangement of component parts are possible within the spirit and scope of the invention as defined in the appended claims.

I claim:

1. A device for producing thrust in response to the application of electrical potentials to the electrodes thereof comprising a support member, a first main electrode mounted on said support member, a second main electrode having an expanded surface with respect to said first main electrode and which is also mounted on said support member in longitudinally spaced relation to said first main electrode, means for applying a high potential between said first and second main electrodes thereby to develop a thrust on said support member longitudinally thereof, a first auxiliary electrode carried by said support member, a second auxiliary electrode disposed in spaced relation laterally of said first auxiliary electrode, and means for applying a high potential between said auxiliary electrodes thereby to develop a thrust on said support member laterally thereof.

2. A device for producing thrust in response to the application of electrical potentials to the electrodes there-

4

of comprising a support member, a first main electrode mounted on said support member, a second main electrode having an expanded surface with respect to said first main electrode and which is also mounted on said support member in longitudinally spaced relation to said first main electrode, means for applying a high potential between said first and second main electrodes thereby to develop a thrust on said support member longitudinally thereof, a first auxiliary electrode carried by said support member, a plurality of second auxiliary electrodes arranged in spaced relation about the axis of said support member and located in spaced relation laterally of said first auxiliary electrode, and means for applying a high potential between said first auxiliary electrode and a selected one of said second auxiliary electrodes thereby to develop a thrust on said support member laterally thereof.

3. A device as defined in claim 2 wherein said first auxiliary electrode is constituted by a cylinder of electrically conductive material.

4. A device as defined in claim 2 wherein said first auxiliary electrode is constituted by a cylinder of electrically conductive material and said plurality of second auxiliary electrodes are arranged in pairs located on diametrically opposite sides of said support member.

5. A device as defined in claim 2 for producing thrust wherein said second auxiliary electrodes are comprised of electrically conductive portions of a ring which surrounds said first auxiliary electrode, said electrically conductive ring portions being insulated from each other by ring portions of dielectric material.

No references cited.

ORIS L. RADER, *Primary Examiner.*